	Technical Guide		TG-19-C-067-E	A
	Made by: pelrom	Date: 29.04.2009	3	

CALIBRE 8421

	Version A
$9'''$ Ø 20.00 mm	
Height on movement 8421	5.40 mm
Power reserve	50 h
Number of jewels	28
Frequency	3.5 Hz (25'200 A/h)

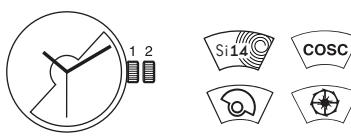

Omega Co-Axial movement, COSC-certified chronometer, self-winding, date, centre seconds. Exclusive luxury decoration. Arabesque Geneva waves, red engravings, black components, barrel with anti-wear coating.

Co-Axial movement escapement wheel with 3-levels, impulse wheel, impulse pinion and drive pinion.

Omega sprung-balance system without index, four white gold regulating screws. Si14 balance-spring (silicon) recognisable by the unique engraving on the balance arm. Adjusting mechanism for balance end-shake. New generation of shock-absorbers. Oscillating weight pivoting on ceramic bearing without lubrication.



	Page
Calibre 8421	1
General information for calibre 8421	3
Balance bridge / Hand fitting height	3
Co-Axial escapement lubrication / Instantaneous rate / Measuring instruments	3
Tightening and untightening torques according to screw thread / Hand fitting	3
Cyclotest equipment / Lubricants / Cleaning and epilam coating / Operation symbols	3
Fitting stages for calibre 8421	4-16
Mechanism 1 assembly	4
Mechanism 2 assembly	5
Order to assembly and checks	6
Barrel fitting and wheel train 1	7
Barrel bridge pre-assembly	8
Barrel bridge assembly	9
Wheel train 2 fitting / Stop lever function check	10
Pallet fork, Co-Axial wheel and pallet fork bridge fitting	11
Wheel train and escapement lubrication	12
Balance fitting / step 1	13
Balance fitting / step 2	14
Mechanism 3 assembly	15
Automatic bridge assembly / Assembling bridge on oscillating weight and fitting	16
Spare parts list for calibre 8421	17-19
Spare parts list	17
Spare parts list	18
Spare parts list	19
Informations spécifiques pour calibre 8421	20-24
Mandatory tools / Balance bridge	20
Sprung-balance / Si14 balance-spring / Information on the movement	21
Crown functions / Components that must not be epilam-treated after cleaning	22
Components that must not be cleaned	22
Technical data / Rate adjustment	23
Disassembling	24



General information for calibre 8421

Complete balance bridge:

For the engraved balance bridge:

See [Working Instruction No. 44](#).

Hand fitting height

Components marked with an asterisk (*) are available in different versions (color, height).

Co-Axial escapement lubrication

See [Working Instruction No. 40](#).

Instantaneous rate

Demagnetise the movement prior to checks according to

[Working Instruction No. 34](#).

Measuring instruments depending on operation types

Operation	Minimum equipment required	Comments
Full or partial maintenance service Co-Axial 3.5 Hz	- Watch Expert II + III (white case) - Chronoscope M1, S1	
Rate adjustment on new watches: (Co-Axial 3.5 Hz)	- Watch Expert I (red case) - Wicometre Professionnel - Chronoscope M1 (former version)	Important: the amplitude will not be indicated precisely. This is acceptable for the rate adjustment only!

Tightening and untightening torques according to screw thread

Screw Ø	Tightening torque target cNm	Untightening torque mini cNm
Ø threads ≤ S 0.50 mm	1.0	0.7
Ø threads S 0.6 mm	1.4	0.8
Ø threads S 0.7 mm	1.8	0.9
Ø threads S 0.8 mm	2.2	1.1
Ø threads S 0.9 mm	2.6	1.3
Ø threads S 1.0 mm	3.0	1.6
Ø threads S 1.2 mm	3.5	2.0
Ø threads S 1.4 and >	4.0	2.5





Hand fitting

To fit the hands, the movement must be held in a movement holder that supports the seconds wheel jewel.

Winding on Cyclotest equipment

Only Cyclotest 4t/min equipment is permitted.

Lubricants



	Moebius SYNT-A-LUBE 9010 (2ml)	Ref. 504 200 0001
	Moebius SYNT HP-HP-500	504 5012
	Moebius SYNT HP-1300 Sans Colorant	504 5013
	Moebius 9504	504 5014
	Kluber P125	504 100 0071

* An asterisk sign means: small quantity of lubricant required

Cleaning and epilam coating









Consult [Working Instruction No. 27](#) for information on cleaning movement parts and coating them with epilam.

Operation symbols

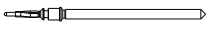

-  Lubrication
-  Check
-  Important

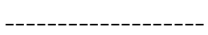

1.0 Parts for assembling

Movement holder	Sliding pinion	Winding pinion	Winding stem	Setting lever
Ref. 506 0117	①	②	③	④
	Ref. 31121	Ref. 31120	Ref. 5101021	Ref. 443/1
				
				

2.0 Pre-lubrication



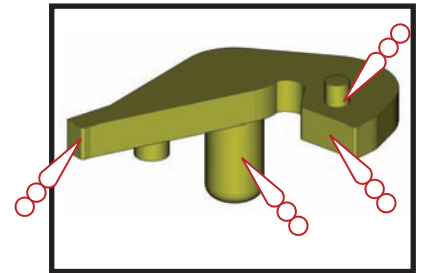
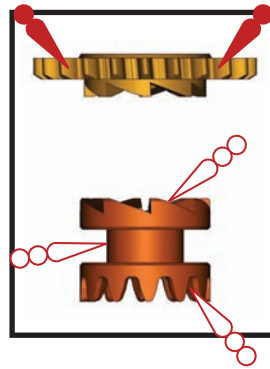
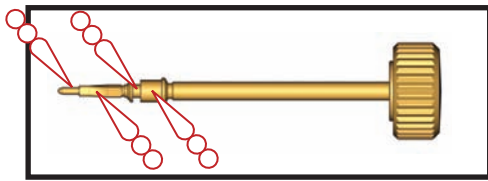



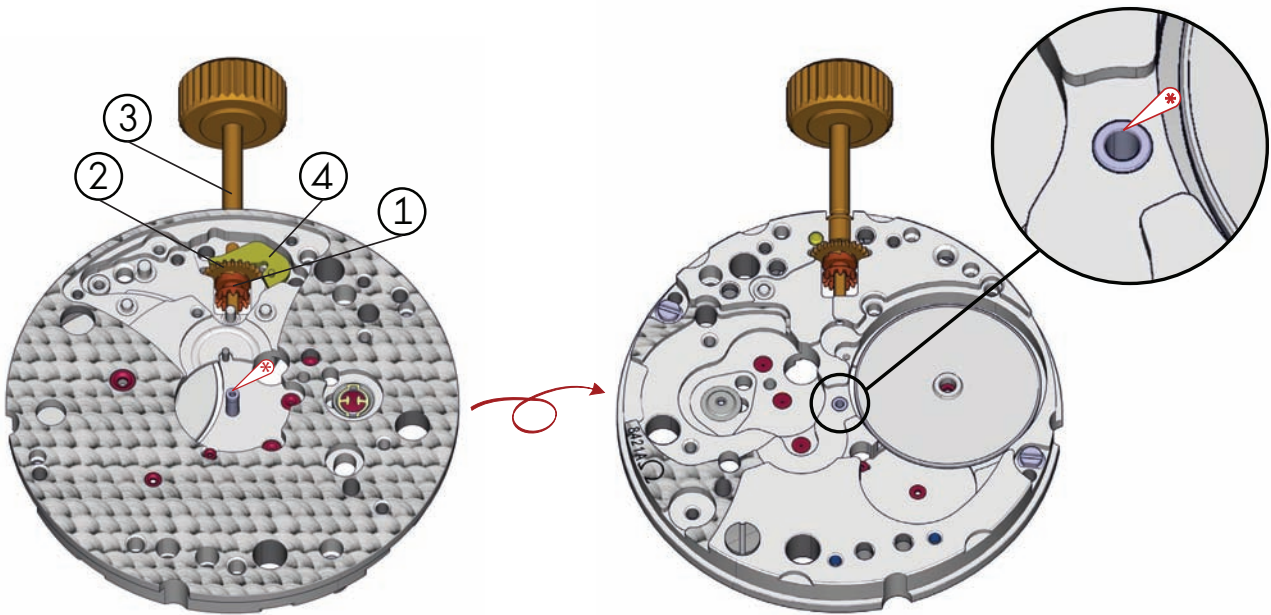

-  Moebius SYNT-A-LUBE 9010
-  Moebius SYNT HP-1300 Sans Colorant
-  Moebius 9504



3.0 Order to assembly

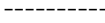

1.0 Parts for assembling

Movement holder	Yoke	Setting wheel	Yoke spring	Setting lever jumper	Screw for setting lever jumper
Ref. 506 0117	①	②	③	④	⑤
	Ref. 435	Ref. 31100	Ref. 61100	Ref. 51090	Ref. 5445
					
					

2.0 Pre-assembling and lubrication



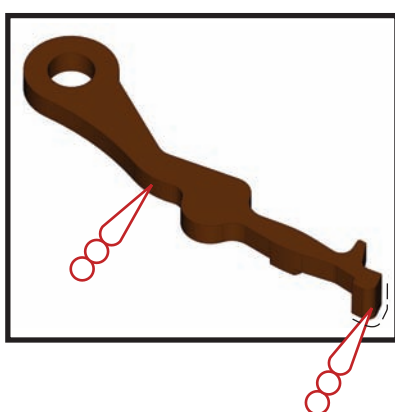
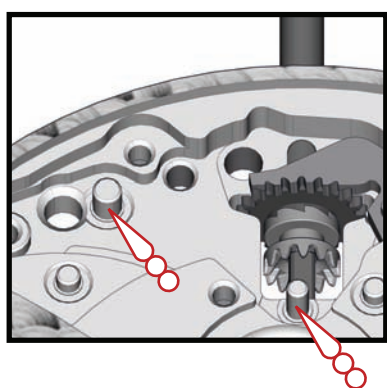

 Moebius SYNT HP-1300 Sans Colorant

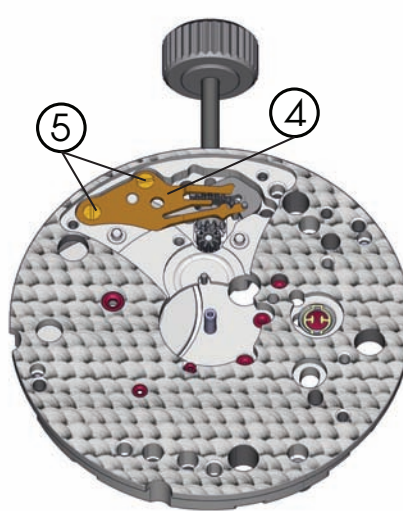
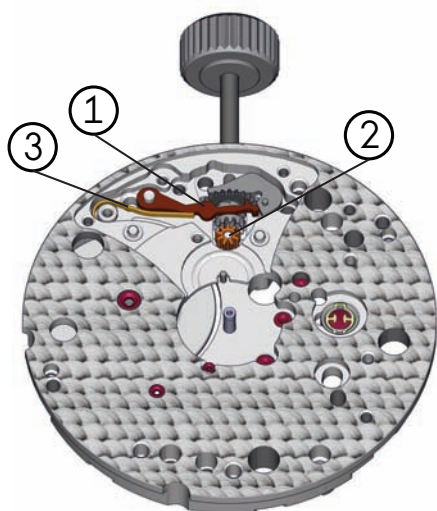

3.0 Order to assembly

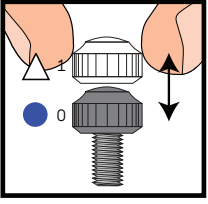
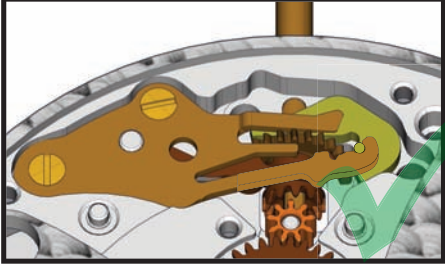

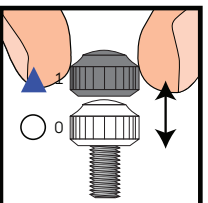
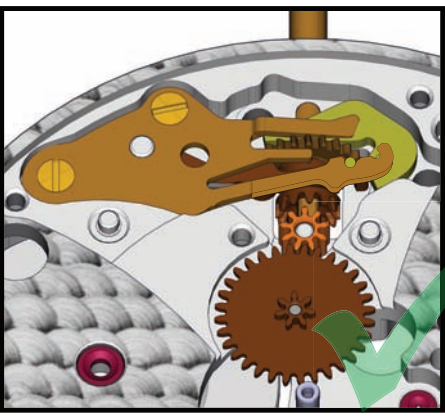





4.0 Order to assembly and checks

 B	Winding stem positions in position 0 or 1.	
		Ko if the winding function is not possible. 
		Ko if the setting wheel is not engaged with the minute wheel (ref. 31041) 

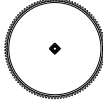



Fitting stages for calibre 8421 - Barrel fitting and wheel train 1

1.0 Parts for assembling

Movement holder	Intermediate wheel	Barrel	Ratchet	Third wheel
Ref. 506 0117	①	②	③	④
	Ref. 30012	Ref. 20010	Ref. 31020	Ref. 30025
				
				

2.0 Pre-assembling and lubrication

 Moebius SYNT HP-1300 Sans Colorant
 Kluber P125



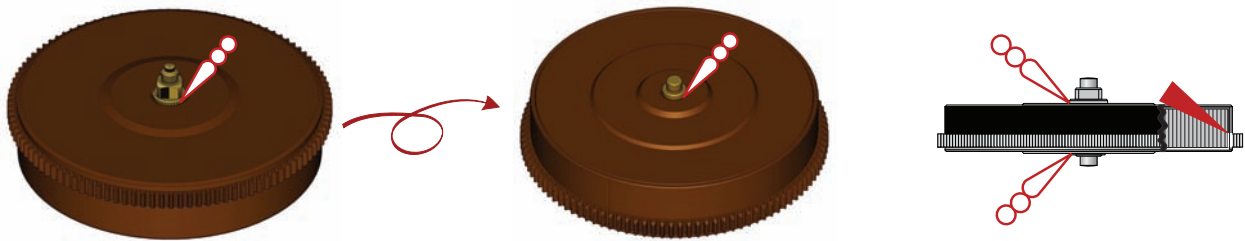



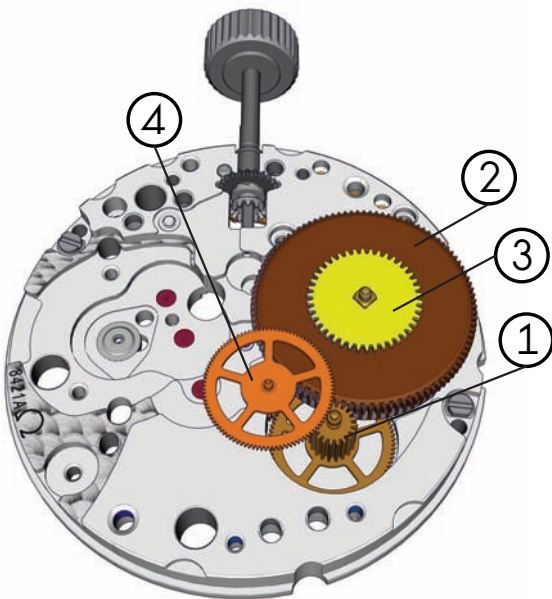













 **Barrel lubrication:**
 Please refer to [Working Instruction 40](#)



3.0 Order to assembly





1.0 Barrel bridge pre-assembly

Movement holder	Intermediate wheel	Wig-wag pinion	Crown wheel	Friction spring	Wig-wag pinion maintaining plate	Crown wheel core	Click spring	Screw for click-spring	Screw for crown wheel	Screw for intermediate crown wheel
Ref. 506 0117	①	②	③	④	⑤	⑥	⑦	⑧	⑨	⑩
	Ref. 31024	Ref. 35064	Ref. 31023	Ref. 61241	Ref. 15139	Ref. 81136	Ref. 61080	Ref. 3566	Ref. 3565	Ref. 3566
										
										

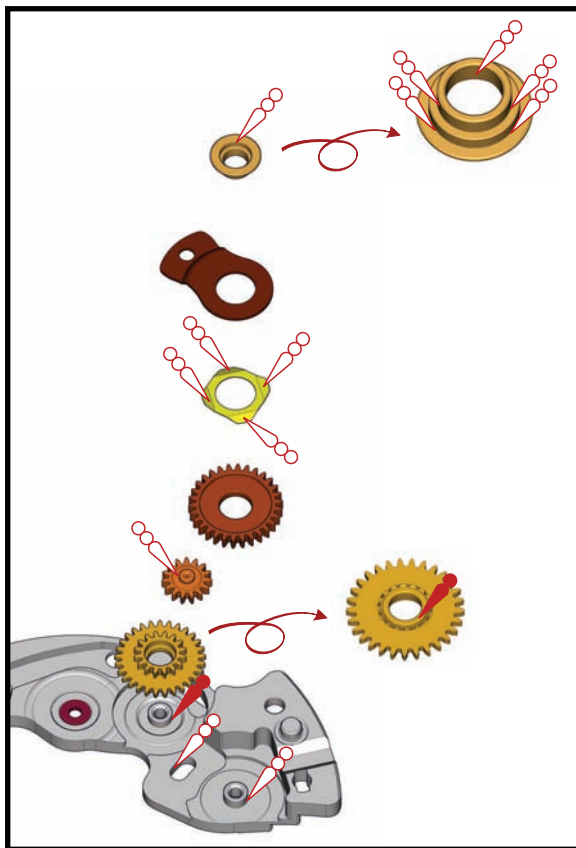
2.0 Pre-assembling and lubrication



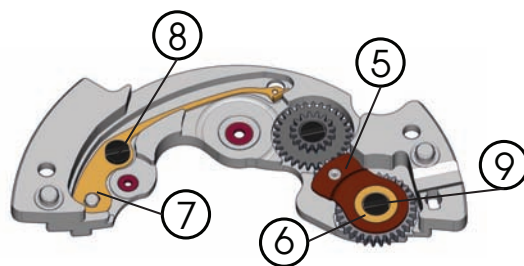
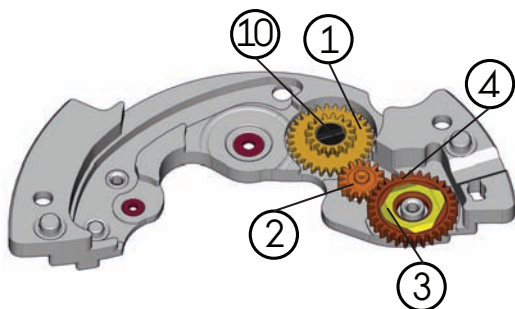

	Moebius 9504
	Moebius SYNT HP-1300 Sans Colorant

3.0 Order to assembly



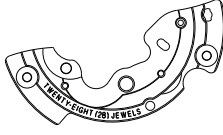





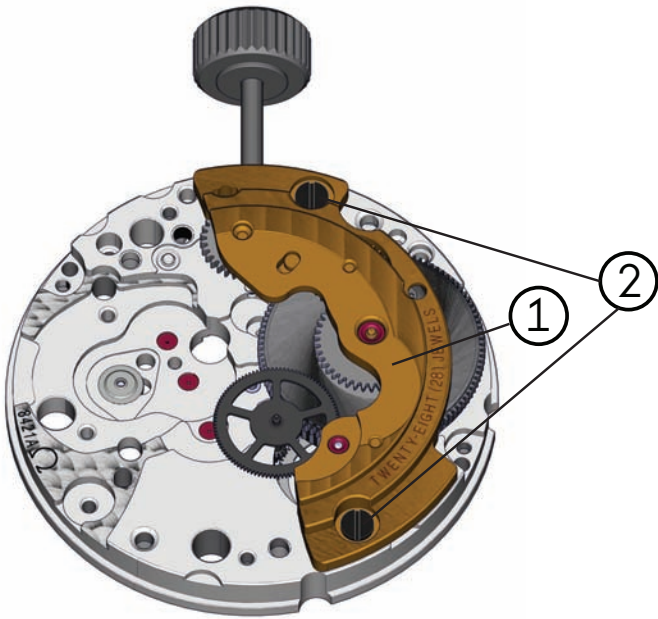

5.0 Parts for assembling

Movement holder	Barrel bridge, pre-assembled	Screw for barrel bridge
Ref. 506 0117	①	②
	Ref. 1004118	Ref. 3561
		
	-----	

6.0 Order to assembly



1.0 Parts for assembling

Movement holder	Intermediate escape wheel	Second wheel	Stop lever	Wheel train bridge	Screw for wheel train bridge
Ref. 506 0117	①	②	③	④	⑤
	Ref. 30039	Ref. 30027**	Ref. 56070	Ref. 1004818	Ref. 3561
					
				-----	

2.0 Order to assembly





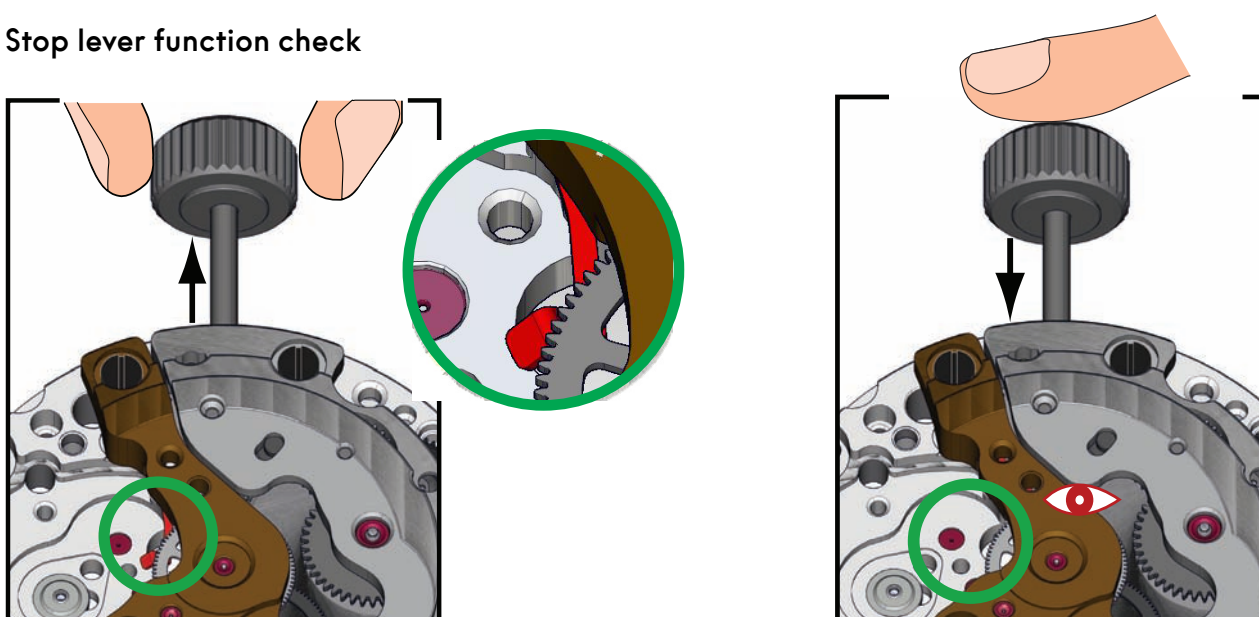





3.0 Stop lever function check

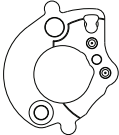

Fitting stages for calibre 8421 - Pallet fork, Co-Axial wheel and pallet fork bridge fitting

1.0 Parts for assembling

Movement holder	Co-Axial wheel	Pallet fork	Pallet fork bridge	Screw for pallet fork bridge
Ref. 506 0117	①	②	③	④ + ⑤
	Ref. 3004019	Ref. 40010	Ref. 1005718	Ref. 3562
				
				

2.0 Order to assembly

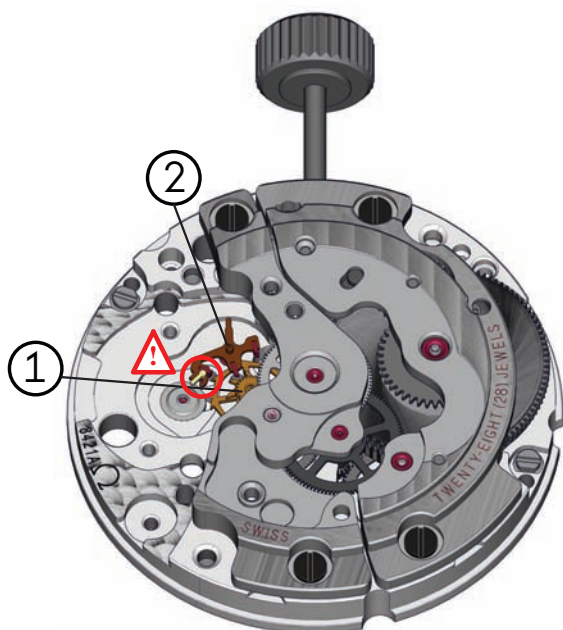

 Never touch the inside of the fork

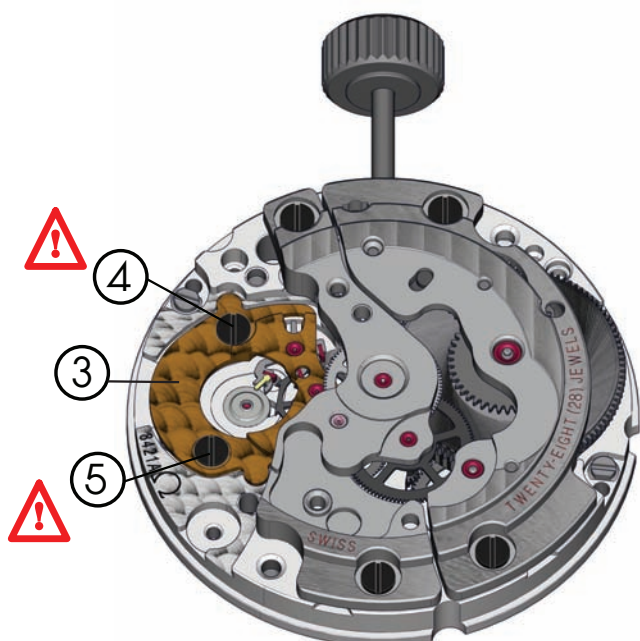

 Tighten the screw ④ which holds the pallet fork bridge in position.

 Tighten the screw ⑤ which maintains the pallet fork bridge in position.





1.0 Lubrication

- Moebius SYNT-A-LUBE 9010
- Moebius SYNT HP-500
- Moebius SYNT HP-1300 Sans Colorant

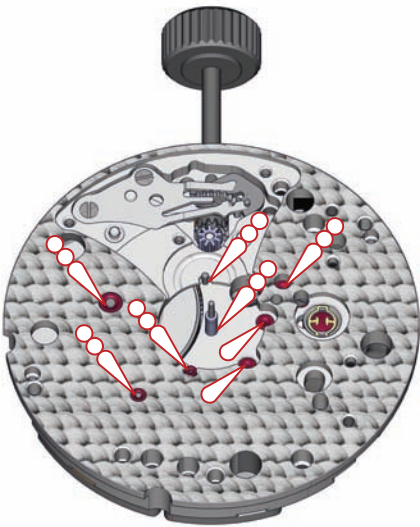
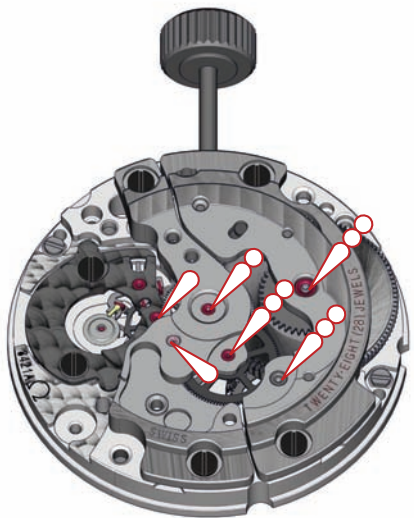
 **Escapement lubrication:**
Please refer to [Working Instruction 40](#)



1.0 Parts for assembling

Movement holder	Balance bridge	Screw for balance bridge
Ref. 506 0117	①	②
	Ref. 1005818	Ref. 3563
		
	-----	

2.0 Positioning and checks

 **Shock-absorber lubrication:**
Please refer to [Working Instruction 40](#)

 **Si14b balance-spring:**
See recommendations on [page 21](#)

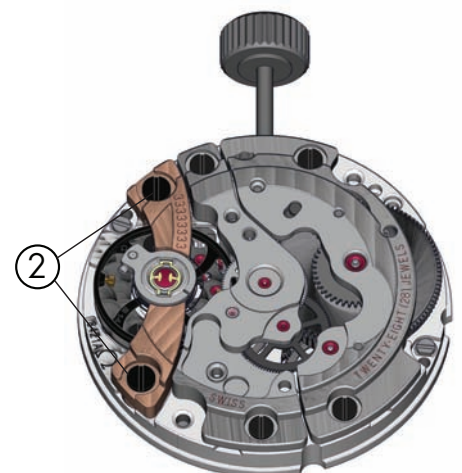
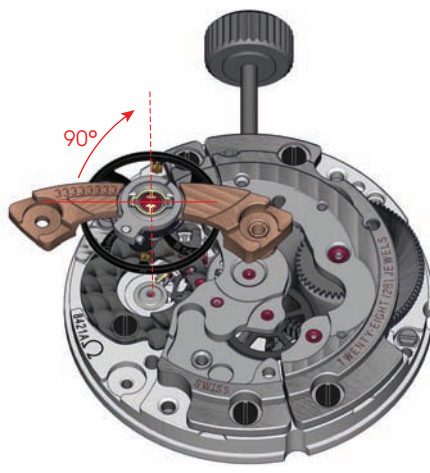
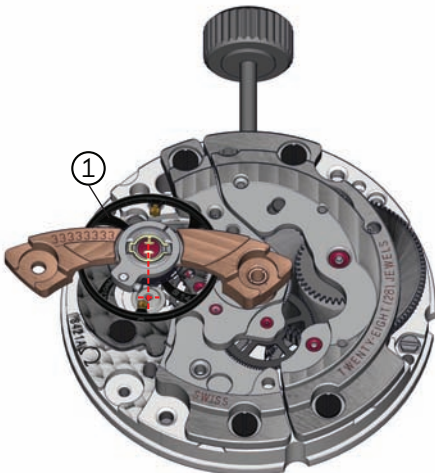
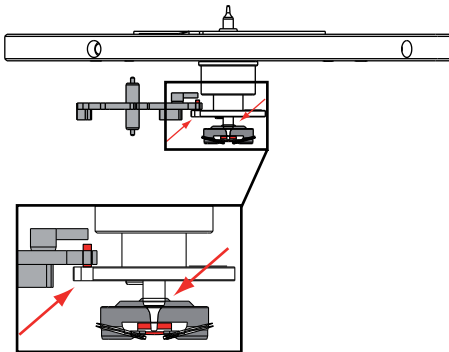

1.0 Checking and adjusting the end-shake of balance

 Check the end-shake. (target value: 0.03 mm).

Correct the end-shake:

Remove the screw ① (long).



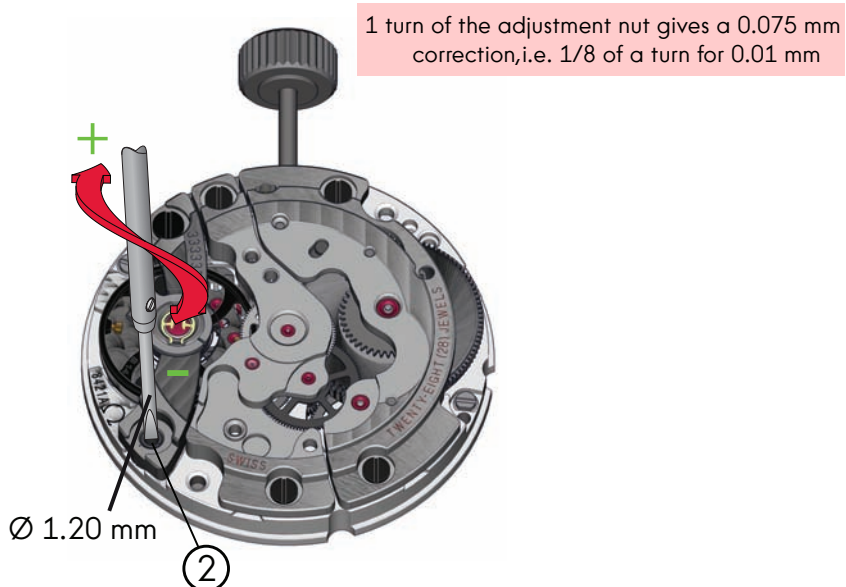
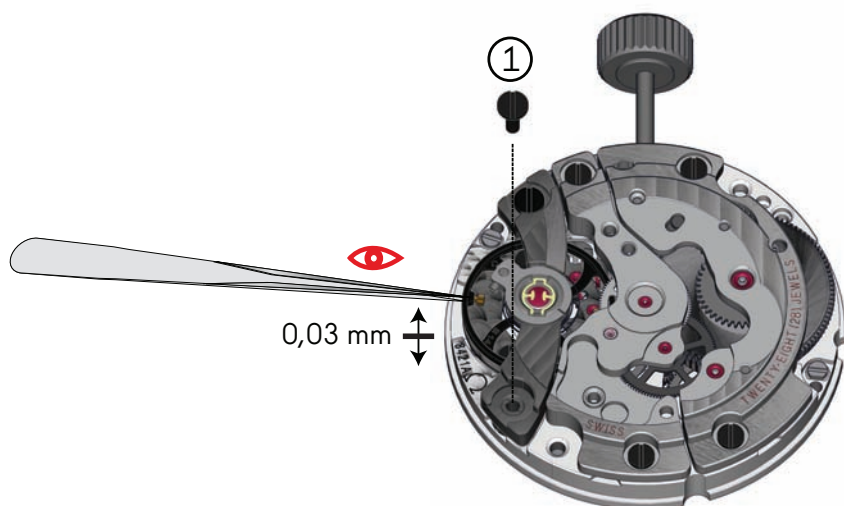

Turn the balance bridge adjustment nut using a screwdriver ②.

Tighten the screw ①.



Fitting stages for calibre 8421 - Mechanism 3 assembly

1.0 Parts for assembling



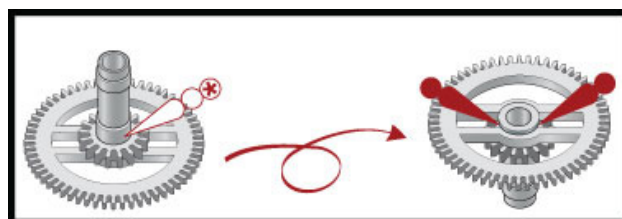
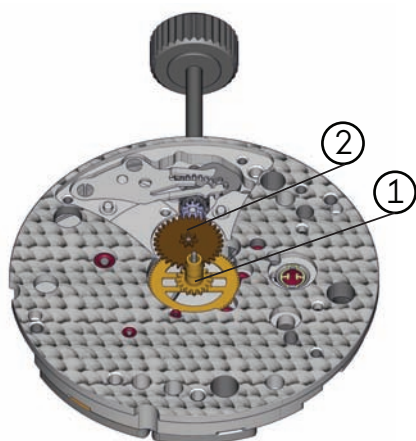

Movement holder	Cannon pinion with driving wheel	Minute wheel
Ref. 506 0117	①	②
	Ref. 31083**	Ref. 31041
		
		

2.0 Order to assembly

➤ Moebius 9504
➤ Moebius SYNT HP-1300 Sans Colorant

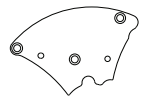

1.0 Parts for assembling





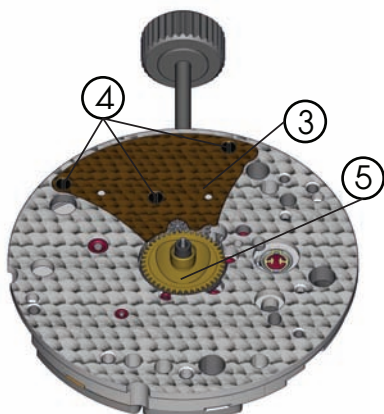



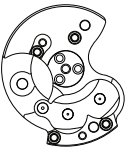

Movement holder	Minute train bridge	Screw for minute train bridge	Hour wheel
Ref. 506 0117	③	④	⑤
	Ref. 10062	Ref. 3566	Réf. 31046**
			
	-----		

2.0 Order to assembly

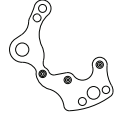



Fitting stages for calibre 8421 - Automatic bridge assembly

1.0 Parts for assembling

Movement holder	Upper automatic bridge	Inversion wheel	Auxiliary reversing wheel	Ratchet wheel driving wheel	Transmission wheel	Lower automatic bridge	Screw for lower automatic bridge
Ref. 506 0117	①	②	③	④	⑤	⑥	⑦
	Ref. 1203018	Ref. 32037	Ref. 32038	Ref. 32033	Ref. 36033	Ref. 1205118	Ref. 3987
							
	-----					-----	

2.0 Pre-assembling and order to assembly



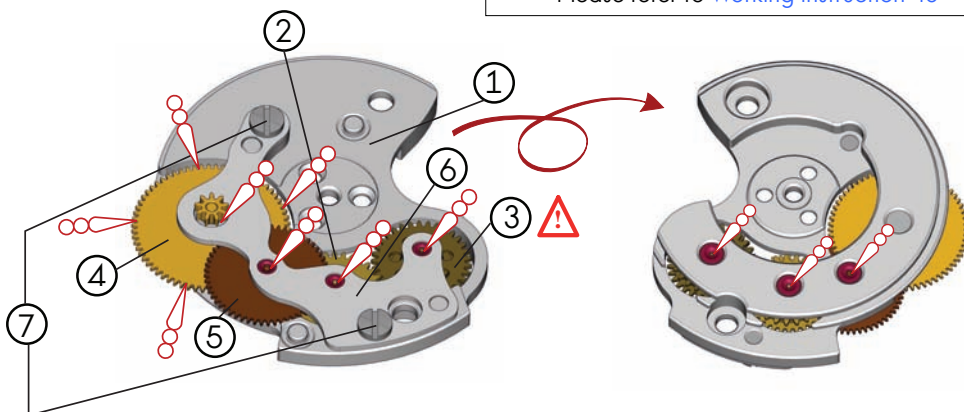
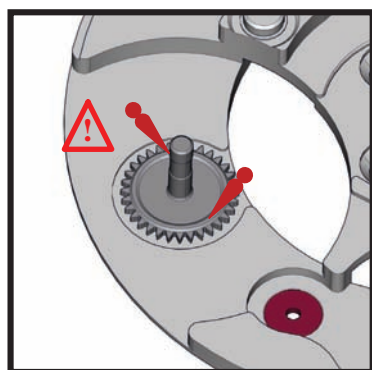

 Moebius 9504
 Moebius SYNT HP-1300 Sans Colorant

 **Big quantity !!**

 **reversing wheel lubrication:**
Please refer to [Working Instruction 40](#)









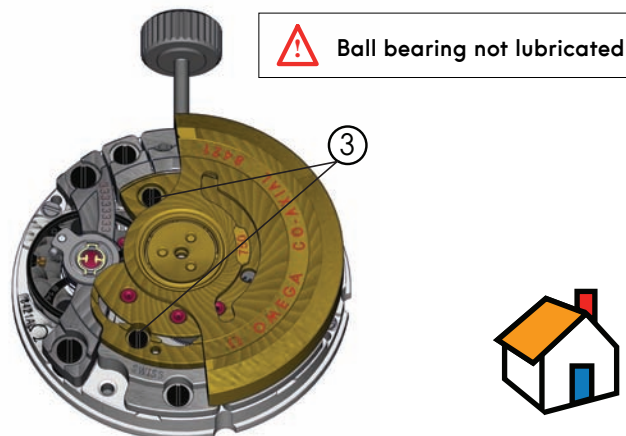
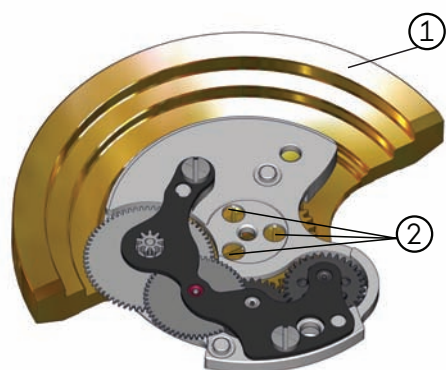



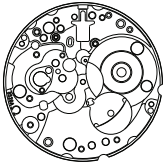
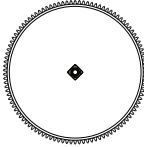

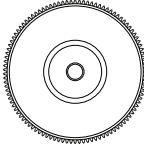

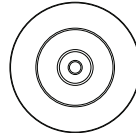

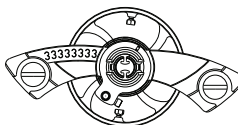
1.0 Parts for assembling

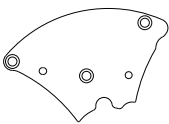
Movement holder	Oscillating weight, pre-assembled	Screw for oscillating weight, pre-assembled	Screw for upper automatic bridge
Ref. 506 0117	①	②	③
	Ref. 2201018	Ref. 5445	Ref. 3564
			
	-----		

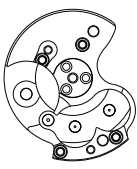

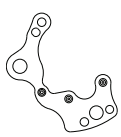















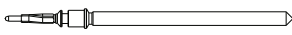









2.1 Assembling bridge on oscillating weight and fitting























Spare parts list for calibre 8421

Main plate, pre-assembled	Version	Reference	Barrel, complete	Version	Reference
	8421A	7228421A100207*		8421A	7228520A20010
Barrel bridge, pre-assembled	Version	Reference	Barrel drum	Version	Reference
	8520A	7228520A1004118		8421A	7228520A20040
Wheel train bridge, pre-assembled	Version	Reference	Barrel cover	Version	Reference
	8421A	7228520A1004818		8421A	7228520A20050
Pallet fork bridge, pre-assembled	Version	Reference	Barrel arbor	Version	Reference
	8421A	7228520A1005718		8421A	7228520A20060
Balance bridge, assembled	Version	Reference	Slipping mainspring	Version	Reference
	8421A	7228521A1005818		8421A	7228520A20100
Minute train bridge	Version	Reference	Oscillating weight, pre-assembled	Version	Reference
	8421A	7228421A10062		8421A	7228421A2201018
Upper automatic bridge, pre-assembled	Version	Reference	Intermediate wheel	Version	Reference
	8421A	7228520A1203018		8421A	7228520A30012
Lower automatic bridge, pre-assembled	Version	Reference	Third wheel	Version	Reference
	8421A	7228520A1205118		8421A	7228520A30025
Wig-wag pinion maintaining plate	Version	Reference	Second wheel	Version	Reference
	8421A	7228520A15139		8421A	7228520A30027*

Spare parts list for calibre 8421

Intermediate escape wheel	Version	Reference	Transmission wheel	Version	Reference
	8421A	7228520A30039		8421A	7228520A36033
Co-Axial wheel	Version	Reference	Pallet fork	Version	Reference
	8421A	7228520A3004019		8421A	7228520A40010
Ratchet wheel	Version	Reference	Balance with timing screws SI	Version	Reference
	8421A	7228520A31020		8421A	7228520A4005019
Crown wheel	Version	Reference	Stud support	Version	Reference
	8421A	7228520A31023		8421A	7228520A40200
Intermediate crown wheel	Version	Reference	Winding stem	Version	Reference
	8421A	7228520A31024		8421A	7228421A5101021
Minute wheel	Version	Reference	Yoke	Version	Reference
	8421A	7228520A31041		8421A	7220720435
Hour wheel	Version	Reference	Setting lever, pre-assembled	Version	Reference
	8421A	7228520A31046*		8421A	7220720443/1
Cannon pinion with driving wheel	Version	Reference	Setting lever jumper	Version	Reference
	8421A	7228520A31083*		8421A	7228421A51090
Setting wheel	Version	Reference	Stop lever	Version	Reference
	8421A	7228520A31100		8421A	7228520A56070
Winding pinion	Version	Reference	Click spring	Version	Reference
	8421A	7228520A31120		8421A	7228520A61080
Sliding wheel	Version	Reference	Yoke spring	Version	Reference
	8421A	7228421A31121		8421A	7228520A61100
Ratchet wheel with driving wheel	Version	Reference	Friction spring	Version	Reference
	8421A	7228520A32033		8421A	7228520A61241
Reversing wheel	Version	Reference	Shock-absorber, upper	Version	Reference
	8421A	7228520A32037		8421A	7228520A70530
Auxiliary reversing wheel	Version	Reference	Shock-absorber, lower	Version	Reference
	8421A	7228520A32038		8421A	7228520A70531
Wig-wag pinion	Version	Reference	In-setting, upper	Version	Reference
	8421A	7228520A35064		8421A	7228500A70640

Spare parts list for calibre 8421

In-setting, lower	Version	Reference	Screw for oscillating weight	Version	Reference
	8421A	7228500A70641		8421A	72207255445
Cap jewel, upper	Version	Reference	Screw for setting lever jumper	Version	Reference
	8421A	7228500A70900		8421A	72207255445
Cap jewel, lower	Version	Reference	Screw for stud	Version	Reference
	8421A	7228500A70901		8421A	7228500A3547
Shock-absorber spring, upper	Version	Reference			
	8421A	7228500A78004			
Shock-absorber spring, lower	Version	Reference			
	8421A	7228500A78005			
Centre tube	Version	Reference			
	8421A	7228520A80400			
Adjustment nut for balance bridge	Version	Reference			
	8421A	7228520A8070318			
Crown wheel core	Version	Reference			
	8421A	7228520A81136			
Screw for barrel bridge	Version	Reference			
	8421A	7228520A3561			
Screw for wheel train bridge	Version	Reference			
	8421A	7228520A3561			
Screw for pallet fork bridge	Version	Reference			
	8421A	7228520A3562			
Screw for balance bridge	Version	Reference			
	8421A	7228520A3563			
Screw for upper automatic bridge	Version	Reference			
	8421A	7228520A3564			
Screw for lower automatic bridge	Version	Reference			
	8421A	72200003987			
Screw for minute train bridge	Version	Reference			
	8421A	7228520A3565			
Screw for wig-wag pinion maintaining plate	Version	Reference			
	8421A	7228520A3566			
Screw for intermediate crown wheel	Version	Reference			
	8421A	7228520A3566			
Screw for click spring	Version	Reference			
	8421A	7228520A3566			



1.0 Mandatory tools

Tools	Ref.
Torx timing key	506 0044
Movement holder, 2-side use	506 0117
Mainspring winders	506 0118
Tool for checking the Co-Axial escapement functions	506 0119
Movement holder for hand setting	507 0125

Fig. 2.0

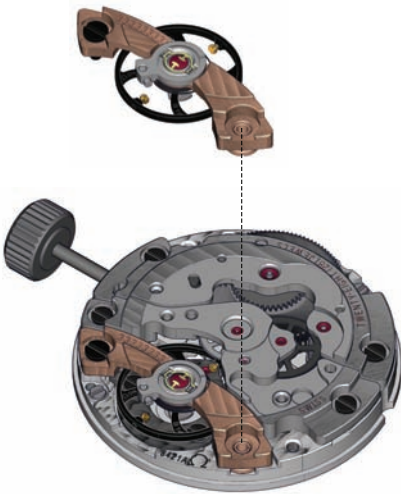

2.0 Balance bridge

The balance bridge is a cross bridge fitted to a fixed seat (movement number side) and an upper, mobile seat (side opposite the movement number) used to adjust the balance end-shake.

As the balance roller is located under the pallet fork, special care should be taken when fitting-in the balance together with the bridge.



Fig. 3.01

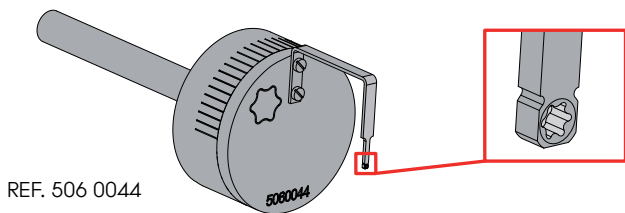

REF. 506 0044

Fig. 3.02

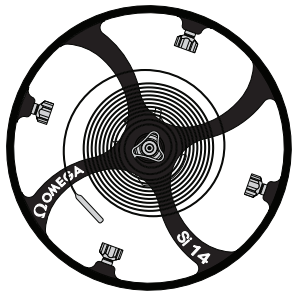

Fig. 3.03

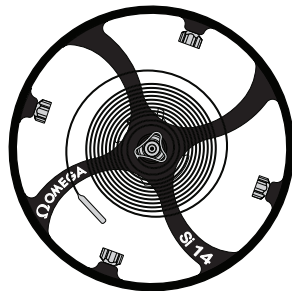

Fig. 3.1

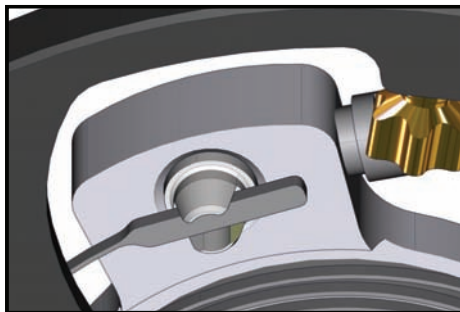
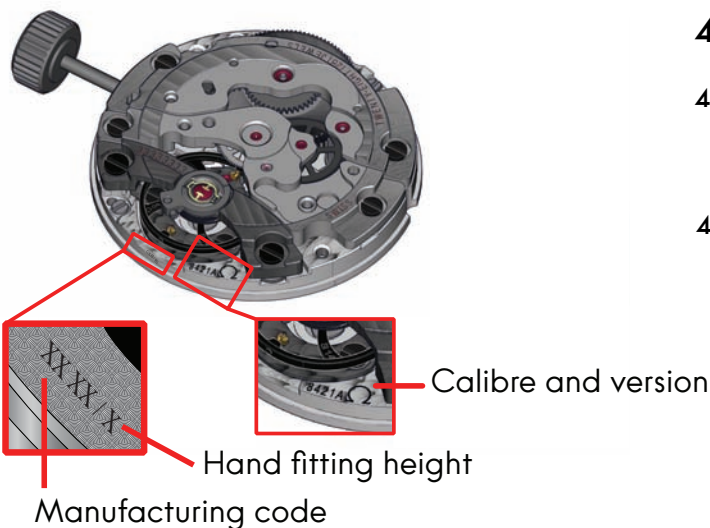

Fig. 4.0



3.0 Sprung-balance

The sprung-balance ref. 4005119 has four timing-screws located inside the balance rim. These screws work in pairs, in opposite positions.

The key can be inserted every 60 degrees.

The engraving on the two adjoining balance arms marks the position of each pair of screws. One arm is engraved **Si 14**, the other **OMEGA**.

A rate deviation is corrected by moving one opposed pair of timing-screws (towards the centre of the balance, Figure 3.02), which reduces its moment of inertia and makes it running faster.

A gain of time is corrected by moving one opposed pair of timing-screws (towards the balance rim, Figure 3.03), which increases its moment of inertia and makes it running slower.

3.1 Si14 balance-spring

The physical properties and unique geometry of the Si14 balance-spring improve the chronometric performances of OMEGA watches equipped with this new oscillator. The rate is more stable over time and less sensitive to external interference.

Major points:

Amagnetic: the Si14 balance-spring is not affected when subjected to a magnetic field.

Impact resistance: excellent resistance factor (maintenance of properties despite shocks). Extremely low influence of fatigue (ageing). No plastic deformation.

Isochronism: improved isochronism owing to its specific geometry. The variances between the different vertical positions of the watch are significantly reduced.

Recommendations:

Cleaning: Manipulation: the sprung-balance system must be handled with care. However, the Si14 balance-spring must not be adjusted. Adjustment, i.e. centring or flattening of hairspring at the collet must never be performed on this component.



4.0 Information on the movement

4.1.1 Calibre, version, manufacturing code and hand fitting height

As shown in Figure 4.0

4.1.2 Ordering starred parts

Movement spare parts should be ordered as follows, in Figure 4.0

Example 7228421A3108301.

The final figure indicates the height of the cannon pinion with driving wheel.



5.0 Crown functions

The crown has 2 positions:

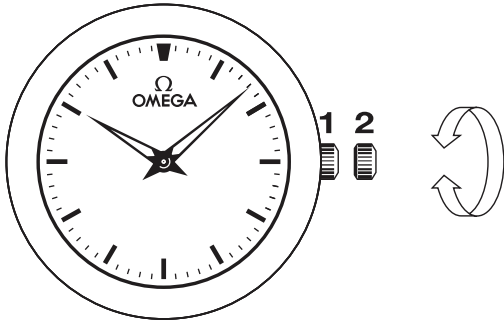

- 1. Normal position (position 1),** wearing position: when the crown is positioned against the case, the crown ensures that the watch is water-resistant. **Occasional winding:** if the watch has not been worn for 50 hours or more, wind it up with the crown in position 1.
- 2. Time setting:** hours–minutes–seconds. Pull the crown out to position 2, the seconds hand will stop. Turn the crown forwards or backwards. Synchronise the seconds by pushing the crown back to position 1 to coincide with a given time signal.

6.0 Components that should not be epilam-coated after cleaning

Description	Reference	
Balance assembled on the balance bridge	4005019 + 1005818	
Complete balance	4005019	
Pallet fork	40010	
Shock-absorber, upper *	70640	
Shock-absorber, lower *	70641	
Pallet fork bridge	1005718	
Barrel, complete **	20010	
Slipping mainspring	20100	



* Do not treat the shock-absorber settings with epilam; the cap jewels should however be treated

** Do not treat the complete barrels with epilam, only the drums, covers and arbours.

6.0.1 Components that must not be cleaned

All black screws	Ref. 3561 (1x)	
	Ref. 3562 (1x)	
	Ref. 3563 (1x)	
	Ref. 3564 (1x)	
	Ref. 3565 (1x)	



7.0 Technical data

7.1 Runners for hand setting and hand setting force

Description	Movement holder for hand setting	No. of runners for hand setting	Minimum force (N)	Maximum force (N)	Support (jewel)
Hour hand	507 0125	5	10	40	no
Minute hand		2	10	40	no
Second hand		1	10	30	yes

7.2 Winding time on Cyclotest (4 rpm)

Complete winding takes 4 hours 10 minutes (movement stopped before the winding, stem in position 3).

7.3 Instantaneous rate

7.3.1 Check of instantaneous rate

Please consult [Working Instructions 5](#) and [28](#) for instructions and tolerances.

Measure particularities according to instrument type used

Instrument type	Co-Axial, 3.5 Hz calibres	Comments
Former Witschi instruments - Watch Expert (red case) - Wicomètre Professionnel - Chronoscope M1 (former version)	Lift angle, set to 38°	3.5 Hz calibres: The frequency parameters (25'200 A/h) should be set manually so that instantaneous is displayed correctly.
	The amplitude is not measured correctly	
New Witschi instruments - Watch Expert II + III (white case) - Chronoscope M1 (updated version) - Chronoscope S1, X1	Lift angle, set to 38°	Test mode: Parameters must be set for «Spe1»!
	All measurements are correct	

7.3.2 Rate adjustment

Fig. 7.3.2

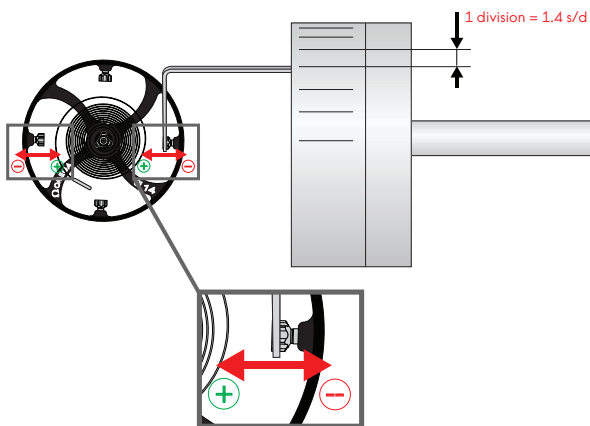

A special timing key tool has been developed to adjust the rate even when the movement is cased in. (see point 3). A line on the scale on the outside of the tool corresponds to 1.4 s/d (Figure 7.3.2).

The correction is always made on the pair of opposed screws located between the non-engraved arms. The other pair of screws between the engraved arms is used for timing during production.



Timing corrections must always be made to the pair of timing-screws between the two, non-engraved arms to prevent an unbalance of the balance.



Fig. 8.0

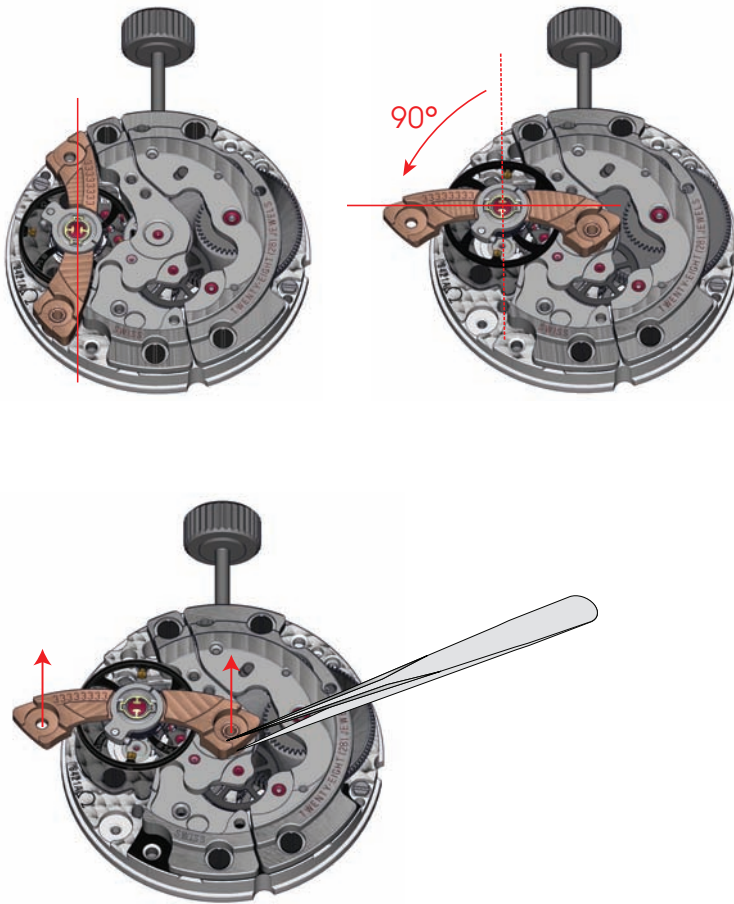

8.0 Disassembling

8.1 Disassembling the balance bridge

The balance bridge is always removed in the reverse direction of the procedure on [page 13](#). The bridge must be turned towards the centre of movement to avoid damaging the balance during the dismantling operation. The bridge may be removed without danger in this position.

8.2 Removing of the winding stem

The winding stem must be in position 2 before the extraction.

